

Introducing...

PK-100D: AN ECONOMICAL WAY TO PROCESS WASTEWATER FROM PARTS WASHERS

SEE BACK SIDE FOR MONEY-MAKING TIPS

LANDA's new PK-100D Porta Kleen now gives dealers a way to take care of wastewater from parts washers.

Until now, a customers' options were limited to:

- Having the wastewater hauled (*very expensive*);
- Putting it down the drain (*usually illegal*); or
- Evaporating the wastewater (*often cost prohibitive for low volumes of wastewater.*)

Now, with the PK-100D, LANDA dealers can build a lucrative service business of processing each month the wastewater from customers' parts washers.

Here's how it works:

- A sump pump, placed in the bottom of the parts washer tank, pumps out the wastewater, puts it through a bag filter housed in a metal canister, and deposits the water in a 55-gallon drum.
- Using a wet vac, the residual sludge is vacuumed out of the tank.
- The sump pump is now used to return the water in the drum back to the parts washer, passing it through the filter one more time.
- The bag is removed from the canister and the



Model PK-100D
Shown with wet vac
and barrel (not included)

sludge in the wet vac is then poured into the bag for dewatering. After it dries, the customer can dispose of it or store for disposal at a later time.

■ The dealer can then recharge the filtered solution with additional chemical to bring it back to the desired strength.

PK-100D PORTA KLEEN SPECIFICATIONS

Sump pump	1/3 hp	Electrical cord	20 feet
Volume	40 gpm	Water hose	1-inch
Electrical	120V, 15 amps	Electrical receptacles	Duplex



PK-100D Porta Kleen

STANDARD FEATURES

LANDA's PK-100D Porta Kleen comes standard with:

- Industrial bag filter housing with 1 bag
- Stainless steel 1/3 hp sump pump (40 GPM)
- Hand truck with pneumatic tires, hooks for the cord and hose, and enclosed tray for pump
- Duplex electrical receptacle with on/off switch (pump and wet vac plug in)
- 20 ft. of electrical cord with 15 amp plug (connection to customers receptacle)
- (2) 10'x1" high temperature hose with cam lock connections
- Operating instructions

NOTE: These do NOT come with the PK-100D:

- 55-gallon drum
- Wet vac

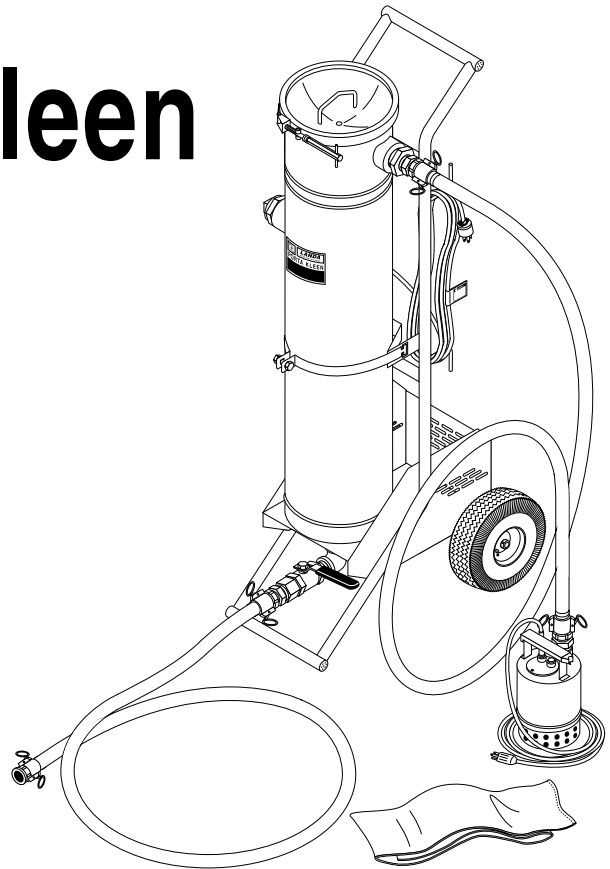

HOW TO RUN A PROFITABLE WASTEWATER PROCESSING SERVICE

Providing a wastewater processing service for your parts washer customers offers dealers several important benefits:

- A profitable side business;
- More opportunities to be in front of your customer so you can identify cleaning needs as they arise; and
- Becoming known as a "total solutions" provider.

For the past four years, *LANDA* Dealer SIM Supply, of Hibbing, Minn., has run a successful program servicing dozens of parts washers the company has sold.

SIM President Dennis Mohny says he has enough contracts to keep one full-time service tech in the field.

Among the customers are mining companies, paper mills

and county and state facilities.

"The key to this thing is that usually the plant doesn't want to hire an additional worker" to clean out parts washers, Mohny says. So the labor savings easily pays for the monthly or bi-monthly service.

Most of SIM's service contracts are signed with the purchase of a parts washer, although SIM even services competitors' parts washers.

■ **How much:** Dealers can charge between \$50 and \$100 per service call.

■ **How long:** Usually the procedure will take 30 to 45 minutes.



DISTRIBUTED BY:

