

40-5,400
SCFM

CDT SERIES
HEATLESS DESSICANT
DRYERS

PRECISION DRYING



CHAMPION

40-5,400 SCFM

CDT SERIES

HEATLESS DESSICCANT DRYERS



HEATLESS DESSICCANT DRYERS



Application Flexibility

Champion CDT Series Heatless Desiccant Dryers were designed to help you meet your goals. Customizable performance technology is integrated into our standard product so it can be tailored to benefit your specific critical compressed air drying application. Now, you have the liberty to personalize the performance of the standard product to adapt to your specific needs.

Across the globe, every application and environment has its own unique dynamics that need to be considered. Traditional desiccant dryer designs asked you to adapt inflexible equipment to meet your critical compressed air treatment applications. Variations in demand, pressure dew point, compressed air purity, and hours of operation have often forced engineers to compromise energy efficiency and system performance for an “off-the-shelf” product. Well...not anymore.

STANDARD CONTROLS ON OUR CDT SERIES HEATLESS DESSICCANT DRYERS OFFER:

- Four Dew Point choices from fixed cycle operating modes
- Eight levels of Purge Air Energy Savings to match to your specific air demand profile
- Controlled purge air shut-down when your air compressor unloads or is turned off

THE OPTIONAL ENERGY SAVING CONTROLLER FURTHER OPTIMIZES THE CDT SERIES WITH:

- Demand driven operating cycles to maximize your return-on-investment
- Automatic Purge Air Control means exact matching to changing system load dynamics
- Complete sensitivity to actual operating conditions minimizes your cost of operation

Dew Point Selection

CDT Series Heatless Desiccant Dryers open up a world of customizable performance opportunities with four standard ISO quality class levels of pressure dew points to choose from. Don't settle for less than the ability to satisfy all of your requirements for clean, dry compressed air. Maybe you need low dew point protection to prevent winter freeze-ups and are satisfied with higher dew points the rest of the year. Simply press the dew point selector button to select a new dew point level that is best for you. The custom-built performance of the CDT Series can be tailored to meet the most critical of applications...yours.

FOUR ISO 8573.1 DEW POINTS TO CHOOSE FROM

Specifying a pressure dew point is not simple work for an engineer. CDT Series dryer designs are optimized with the flexibility to meet your needs.

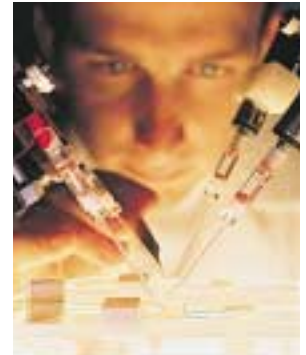

ISO 8573.1 Class	Dew Point	Remaining Moisture**		Cycle Time & Mode	
		ppmw	mg/m ³	CDT Series	Optional Energy*** Saving Controller
1	-100°F (-73°C)*	0.12	0.15	4 min. fixed	--
2	-40°F (-40°C)	10	12	10 min. fixed	Demand
3	-4°F (-20°C)	81	97	16 min. fixed	Demand
4	+38°F (+3°C)	610	730	24 min. fixed	Demand

* This performance exceeds Quality Class 1 set at -94°F (-70°C)

** At 100 psig (7 bar)

*** The Optional Energy Saving controller also offers fixed cycle settings

Critical Applications Use

CDT Series Heatless Desiccant Dryers and CFF Series Filters provide “critical use” applications of compressed air with a highly engineered quality air treatment system. “Critical uses” of compressed air have zero tolerance for contaminants whose presence will lead to manufactured product spoilage and rejection from a quality assurance standpoint. A carefully engineered desiccant dryer design provides a reliable method to remove moisture as a water vapor while coalescing filters remove solid particles, liquid water droplets, liquid oil and oil vapors from the compressed air system.



CDT Series Dryers offer Pressure Dew Points to -100°F (-73°C)

Moisture (water vapor) is present in ambient air as a gas and cannot be filtered. Adsorbents present in the CDT Series remove water vapor to prevent it from condensing into harmful liquid water droplets inside compressed air systems. Microelectronic and pharmaceutical manufacturing are examples which cannot tolerate the presence of any moisture.

CFF Series Coalescing Filters Remove Water Droplets and Solid Particles to 0.01 Micron

Water droplets are formed by the condensed water vapor present in ambient air. Solid particles come from ambient air contaminants like dust and from rusted, oxidized pipework. They can cause pneumatic equipment to malfunction and trigger instrument and control failures.

CFF Series Filters Remove Oil and Oil Vapors for Oil-Free Air

Liquid oil and oil vapors are introduced by compressor coolants and by hydrocarbon vapors present in ambient air. Oil-free compressed air is particularly important in food and pharmaceutical processes where direct and indirect contact with compressed air occurs. Oil contamination of food and drug products can generate significant liability issues and manufacturing spoilage costs.

Refined Engineering

Saturated air enters the bottom of Tower 4A of the two dual towers filled with a bed of activated alumina desiccant through inlet switching valve 3A. The activated alumina adsorbs the moisture in the compressed air as the air flows upward. Upflow drying protects the bed from water and heavy contaminants by separating them from the air stream as they enter the tower. Cleanable, stainless steel, flow diffusers ensure even flow distribution through the bed which avoids channeling. The dry air exits the dryer through Shuttle Valve 5 on models CDT40 through CDT-450. On models CDT-590 through CDT5400, the dry air exits through Check Valve 5A.



For regeneration, a portion of the dried air flows through purge adjusting valve 6 and orifice 7 and is reduced to near atmospheric pressure. This dry, low pressure air (purge air) regenerates the activated alumina in Tower 4B by carrying off the moisture collected during the drying stage. The purge air is then exhausted to atmosphere through purge/repressurization valve 9B and purge muffler 10B.

After regeneration, purge/repressurization valve 9B closes and Tower 4B repressurizes to line pressure. Inlet switching valve 3B then opens, inlet switching valve 3A closes, and purge/repressurization valve 9A opens. Inlet air is now dried in Tower 4B while Tower 4A is being regenerated.

The two towers will continue to alternate between drying and regeneration so that dry desiccant is continually exposed to the air stream.

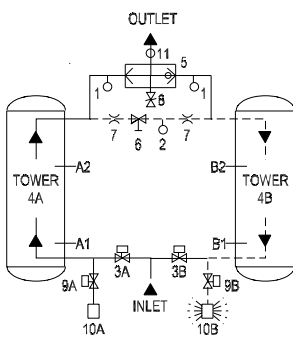

1. Pressure Gauges
 2. Purge Pressure Gauge
 3. Inlet Switching Valves
 4. Desiccant Drying Towers
 5. Shuttle or Check Valve(s)
 6. Adjustable Purge Rate Valve
 7. Purge Orifice(s)
 8. Safety Valve(s)
 9. Purge and Repressurization Valves
 10. Purge Mufflers
 11. Moisture Indicator
- A & C Left Tower Suffix(es)
B & D Right Tower Suffix(es)

CDT40–CDT450
TOWER 4A DRYING
TOWER 4B REGENERATING

Process Stream —————
Purge Stream - - - - -

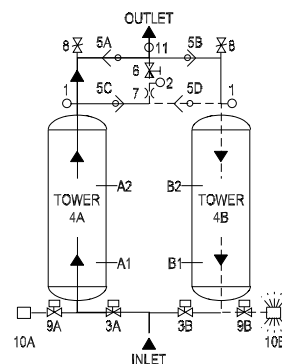

CDT590–CDT5400
TOWER 4A DRYING
TOWER 4B REGENERATING

Features

MODELS CDT40-450

Models CDT40-450 are engineered to benefit you with a clean, streamlined package. This design has a small footprint to increase your available floor space. Inlet and Outlet piping is conveniently located at the back to aid in installation and serviceability. Discharge piping exits the back of the towers to reduce the overall height of the package. Low headroom installations such as hospitals and laboratories will benefit from the reduced height of the overall package.



FRONT

STANDARD INSTRUMENTATION

- Left and right tower pressure gauges
- Purge pressure gauge
- Moisture indicator – alerts operator of elevated dew point
- Standard pilot air filter and regulator

TWO ENERGY SAVINGS CONTROLLERS TO CHOOSE FROM

- Standard controller includes fixed savings potential with Purge Optimizer
- Optional Energy Saving Controller for exact automatic purge savings

LARGE DESICCANT BEDS ENSURE CONSISTENT DEW POINTS

- 0.6 lbs (0.27 kgs) of desiccant per tower per scfm guarantees dry air
- 4.8 seconds of contact time for saturated air with the desiccant
- 30% extra desiccant provided to compensate for natural bed aging over the expected 3 to 5 years bed life
- Large, cleanable, stainless steel flow diffusers ensure even flow distribution and eliminate channeling through the bed
- Tower design saves 98% of the heat of adsorption

CERTIFIED DESIGNS FOR SAFETY

- ASME code constructed vessels comply with codes. Models 115 and larger are stamped. Models are UL and CSA certified.
- Pressure relief valves on each tower mounted after flow diffusers to prevent clogging
- Heavy-duty mufflers for quiet operation
- NEMA 4,4X electrical construction standard

OPTIONAL CFF SERIES FILTER PACKAGES WITH BYPASS SYSTEMS

- Convenient factory-mounted CFF Series prefilter/afterfilter packages with bypass available
- Optional Element Monitors inform of optimal element change-out time

RUGGED AND RELIABLE VALVES OFFER HIGH CYCLE LIFE

- CDT40-CDT450 use a unitized shuttle valve for discharge control and, reliable pilot operated angle-seated pneumatic valves (solenoid actuated) to ensure top quality inlet switching and purge repressurization performance.
- Accurate purge flow control valve
- Pilot air is filtered by a CFF Series Grade C, 1 micron Filter
- NAMUR mount pilot valves

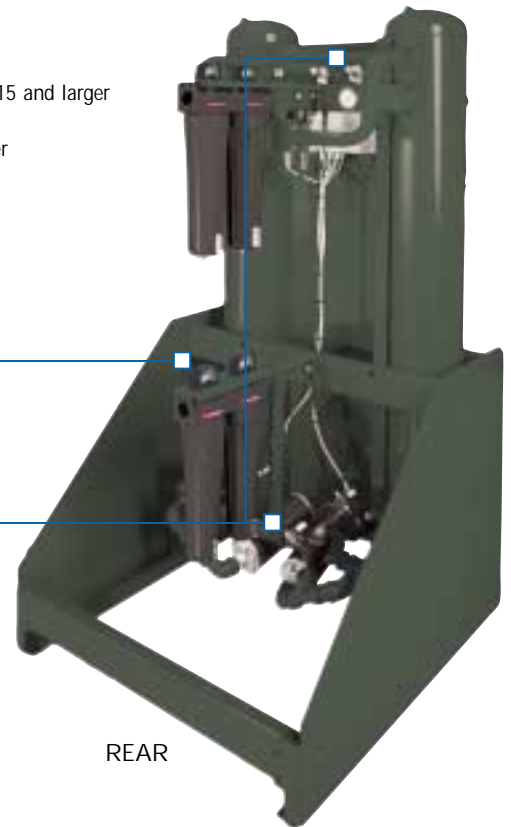

REAR

MODELS CDT590-5400

Models CDT590-5400 are engineered to benefit you with an extremely heavy-duty robust package designed for the most demanding industrial applications. Our in-line piping arrangement reduces installation times for those bigger installations. Rugged high capacity components ensure long-life for tough applications in hostile environments.

RUGGED AND RELIABLE VALVES OFFER HIGH CYCLE LIFE

CDT590-CDT5400 use soft-seated check valves for discharge control and, air operated butterfly valves and dual piston, double-acting rack and pinion actuators to ensure top quality inlet switching and purge repressurization performance.

Accurate purge flow control valve

Pilot air is filtered by a CFF Series Grade C, 1 micron Filter

NAMUR mount pilot valves

STANDARD INSTRUMENTATION

Left and right tower pressure gauges

Purge pressure gauge

Moisture indicator – alerts operator of elevated dew point

Standard pilot air filter and regulator

TWO ENERGY SAVINGS CONTROLLERS TO CHOOSE FROM

Standard controller includes fixed savings potential with Purge Optimizer

Optional Energy Saving Controller for exact automatic purge savings

LARGE DESICCANT BEDS ENSURE CONSISTENT DEW POINTS

0.6 lbs (0.27 kgs) of desiccant per tower per scfm guarantees dry air

4.8 seconds of contact time for saturated air with the desiccant

30% extra desiccant provided to compensate for natural bed aging over the expected 3 to 5 years bed life

Large, cleanable, stainless steel flow diffusers ensure even flow distribution and eliminate channeling through the bed

Tower design saves 98% of the heat of adsorption

CERTIFIED DESIGNS FOR SAFETY

ASME code constructed vessels comply with codes. Models 115 and larger are stamped.

Models are UL and CSA certified.

Pressure relief valves on each tower mounted after flow diffusers to prevent clogging

Heavy-duty mufflers for quiet operation

NEMA 4,4X electrical construction standard



Control Operating Costs

CDT Series Heatless Desiccant Dryer Controllers are designed to help engineers' meet their goals for consistent dew point control and to ensure that their company can control operating costs. Invest in a CDT Series dryer and you gain rugged reliability and premium performance in a package that you can customize to meet your specific requirements. The key to controlling your cost of operation is to first identify the nature of your plant air demand profile and then select the Controller that best serves your needs. All CDT Series dryers come equipped with RS-232 communication ports.



STANDARD CDT SERIES CONTROLLER

The Standard Controller provides a wealth of features that allow you to personally customize the dryer to meet the anticipated needs of your plant load. Purge Optimizer can be programmed to extend the repressurization cycle and save purge air at specific percentages of maximum load. You benefit from increased productivity and reduced operating costs.

Standard CDT Series Controllers include:

- Dew Point selections of - 100°F, -40°F, -4°F, and +38°F operate from Fixed Mode regeneration cycles
- Purge Air savings to 70% of full capacity to match up to your largest air demand
- User programmable purge air shut-down capabilities can be synchronized to your air compressor
- Switches for ISO Class dew point, On/Off, Alarm and Service reminder reset
- LED lights that express power-on, valve status, and tower status
- Normal or severe duty selectable LED lights that warn when service is due on filters, drains, valves and desiccant

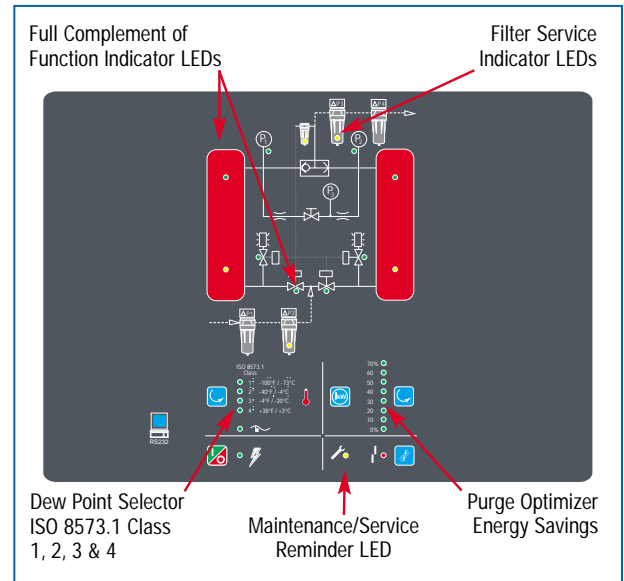

OPTIONAL CDT SERIES ENERGY SAVING CONTROLLER

The Optional Energy Saving Controller was engineered to continually adapt to ever changing air demand profiles to assure you of the straightest path to a rapid Return-On-Investment. Patented technology in Demand Mode senses the heat generated by your actual plant load and automatically adapts the regeneration cycles to match those load changes.

The Energy Saving Controller is packed with features to further optimize the CDT Series with:

- Maximum energy savings
- Consistent Demand Mode dew point control of -40°F, -4°F, and +38°F (-100°F in Fixed Mode only)
- Automatic Purge Air control
- Exact load matching sensitivity to adapt to system variations
- Alarm LED lights for tower switching failure, filter monitor signals, electronic demand drain alarms on filters
- Vacuum fluorescent text display expresses percentage of energy saved in real-time, operating mode and service reminders

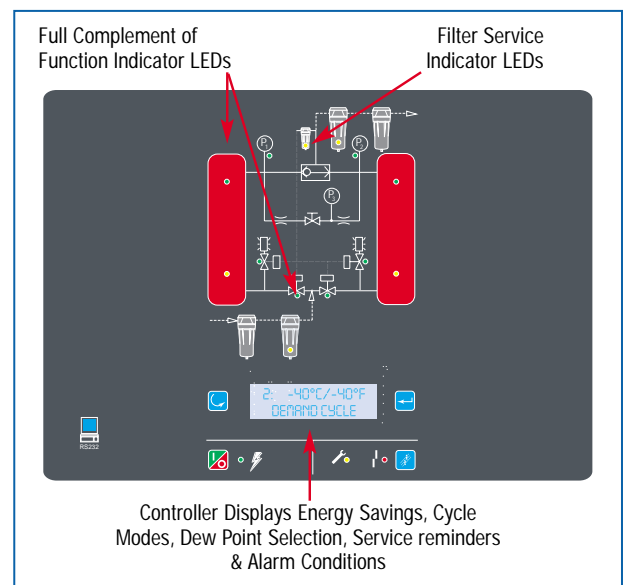

Purge Air Savings

Energy is consumed in the form of purge air to prepare the "off-line" desiccant tower for its next cycle of operation by a process called regeneration. You have the ability to optimize your purge air consumption to achieve energy savings that will pay you dividends for many years to come. The following describes variations in plant operations that dictate which Controller selection may deliver your best value.

STANDARD PURGE OPTIMIZER SAVINGS:

Facilities operating at a constant level of air demand benefit the most from the Purge Optimizer feature. Ordinary heatless dryer designs offer zero purge air savings. The Purge Optimizer allows you to select purge air savings of 10%, 20%, 30%, 40%, 50%, 60% or 70% of inverse proportion to your air demand. For example, you can elect to save 30% of your purge air costs if your maximum air demand is 70% of full rated capacity; 40% savings at 60% load, 50% at 50% and so on. This feature is invaluable if your maximum load levels remain fairly constant and you are on a limited budget.

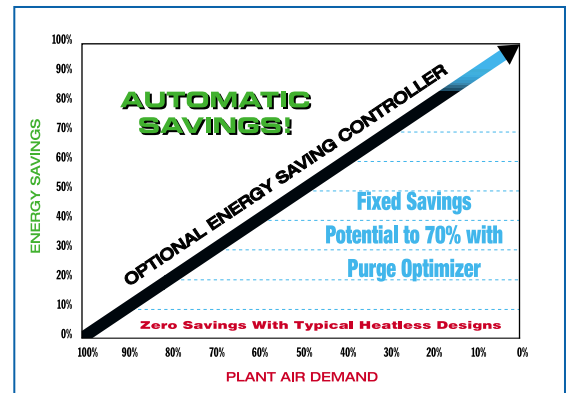

OPTIONAL ENERGY SAVING CONTROLLER:

Events as transparent as lunch and coffee breaks represent energy saving opportunities that typically reflect 19% of every shifts working hours. Add in production changes and machine down time and there are more valleys than peaks on the demand chart. This patented Controller uses thermistors to carefully monitor the natural temperature changes that occur during each drying and regeneration cycle. The Controller acts on that data to precisely manage your systems purge air needs. No intervention is required on your part. Maximum energy efficiency is achieved. You save up to 84% on purge air energy costs...automatically.

World Class Filtration

Champion CFF Series Filters complete the integrity of your critical use air treatment system and are available in a variety of sizes and grades. Compressed air quality and desiccant bed life are dependent on clean compressed air. Compressed air must be prepared prior to entering the desiccant dryer.

Normal installations include an CFF Series Grade C (1 micron solid particles) prefilter followed by an CFF Series Grade E or Grade F oil removal filter. Grade E (to 0.008 ppm) filters are used for ISO 8573.1 Class 2,3 or 4 requirements. Grade F (0.0008 ppm) satisfies the needs of Class 1 pressure dew points. An CFF Series Grade D (1 micron, reverse-flow) particulate filter is the right choice for installation after the dryer to collect the fine desiccant dust and prevent it from migrating downstream. Then, if it is technically oil-free air you need, complete the filter system with a Grade G Oil Vapor Removal Filter.

OPERATIONAL SECURITY WITH THE ELEMENT MONITOR

Heightening the operational security of your CFF Series Filters is as simple as specifying you want the optional Element Monitor included with each filter you order. Rely on your Champion Distributor to assist you in selecting the best combination to satisfy your specific requirements.



SIZING INFORMATION

TABLE 1

Model	Inlet Flow @ 100 psig, (7 bar) scfm	Height	Dimensions (in.) Width	Depth	Connections (in.)	Weight (lb.)
CDT40	40	74	26	26	1/2" NPT	365
CDT60	60	76	26	26	3/4" NPT	445
CDT90	90	76	33	33	3/4" NPT	575
CDT115	115	76	33	33	1" NPT	685
CDT165	165	76	33	33	1" NPT	685
CDT260	260	80	44	44	1-1/2" NPT	1010
CDT370	370	81	44	44	1-1/2" NPT	1215
CDT450	450	82	44	44	1-1/2" NPT	1350
CDT590	590	95	52	48	2" NPT	2205
CDT750	750	97	52	48	2-1/2" NPT	2705
CDT930	930	102	58	56	2-1/2" NPT	3228
CDT1130	1130	104	62	57	3" ANSI Fig.	3740
CDT1350	1350	109	63	57	3" ANSI Fig.	4252
CDT1550	1550	109	77	68	4" ANSI Fig.	4796
CDT2100	2100	106	85	75	4" ANSI Fig.	5100
CDT3000	3000	121	80	89	6" ANSI Fig.	8500
CDT4100	4100	105	91	85	6" ANSI Fig.	9900
CDT5400	5400	122	102	92	6" ANSI Fig.	12000

* BSP connections and DN Fig available.
Dimensions and weights are for reference only. Request certified drawings for construction purposes.

TABLE 2

Operating Pressure	psig	60	70	80	90	100	110	120	130	140	150	175	200	225	250
	bar	4.2	4.9	5.6	6.3	7.0	7.7	8.4	9.1	9.8	10.5	12.3	14.1	15.8	17.6
Multiplier		0.65	0.74	0.83	0.91	1.00	1.04	1.08	1.12	1.16	1.20	1.29	1.37	1.45	1.52

To determine inlet flow at pressures other than 100 psig (7 kgf/cm²) multiply inlet flow at 100 psig from Table 1 by the multiplier that corresponds to your operating pressure from Table 2.

OPERATING PARAMETERS

- Maximum Working Pressure 150 psig standard. Optional 250 psig available. Higher pressures are available
- Minimum Operating Pressure for 150 psig models are 60 psig
- Minimum Operating Pressure for 250 psig models are 120 psig
- Maximum inlet or ambient air temperature 120°F (49°C)
- Pressure drop at rated flow is less than 5 psi
- Standard voltages: Controllers automatically identify and adapt the CDT Series to the following ranges of electric conditions:
 - Single Phase
 - Volts AC 85-264
 - Hertz 47-63
 - Volts DC 11.5-28
 - Commonly referenced as 120V/1/60, 110/1/50, 240/1/60, 220/1/50, 12 VDC, 24 VDC,
- NEMA 4,4X Standard

NOTES

Inlet flows are established in accordance with CAGI Standard ADF-200: Dual Stage Regenerative Desiccant Compressed Air Dryers-Methods for Testing and Rating. Conditions for rating dryers are: inlet pressure of 100 psig, inlet temperature saturated at 100°F.

Average purge flow rate is the amount of purge air used during the regeneration portion of the purge cycle (purge/repressurization valve open) plus the volume of air used to repressurize the tower after the purge/repressurization valve closes averaged over the cycle time. At 100 psig, the average purge rate is: 14.4% (13.7% for regeneration + 0.7% for repressurization) of rated inlet flow for dryers operating on a 10 minute cycle; 15.5% (13.7% for regeneration + 1.8% for repressurization) for dryers on a 4 minute cycle.

Outlet Flow: To determine flow of air available at outlet of dryer, subtract purge flow from inlet flow.



www.championpneumatic.com

Champion
1301 North Euclid Avenue
Princeton, Illinois 61356 USA
Phone 815/875-3321
Fax 815/872-0421
E-mail: Champion@championpneumatic.com

Plants in Princeton, IL, and Manteca, CA

Due to Champion's continuing product development program, specifications and materials are subject to change without notice or obligation.

ONE COMPANY.
ONE SOURCE.

